

## Authors

- **Prof. Dr. Muhammad Atif**  
(PhD Computer Science)  
Professor of Computer Science, Lahore Garrison University.
- **Prof. Dr. Syed Waqar ul Qounain Jaffry**  
(PhD Computer Science) Chairman Dept. of IT,  
University of The Punjab, Allama Iqbal Campus (Old Campus) Shahrah-e-Quaid-e-Azam, Lahore.

## External Review Committee

- **Dr. Arshad Ali**  
(PhD Computer Science and Telecommunication)  
Associate Professor, Department  
Head (Cyber Security),  
Lahore Garrison University.
- **Dr. Mudasser Naseer**  
(PhD Computer Science)  
Associate Professor(CS),  
Department of CS & IT,  
University of Lahore Defense Road, Lahore
- **Mrs. Tabinda Muqaddas**  
Assistant Professor, Head of Department (CS),  
Govt. Associate College for Women,  
Gulshan Ravi, Lahore.
- **Prof. Dr. Asif Shahzad**  
(PhD Computer Science)  
Chairman Department of  
Computer Science,  
University of Engineering and Technology, Lahore
- **Dr. Nadeem Iqbal**  
(PhD Computer Science)  
Associate Professor(CS),  
Department of CS & IT,  
University of Lahore Defense Road, Lahore
- **Dr. Abdul Sattar**  
(PhD Computer Science)  
Assistant Professor (CS),  
Lahore Garrison University.
- **Dr. Adeel Nisar**  
(PhD Computer Science)  
Assistant Professor(CS),  
University of The Punjab, Allama Iqbal Campus  
(Old Campus), Shahrah-e-Quaid-e-Azam, Lahore.
- **Mr. Fahad Asif**  
EST (CS),  
Govt. Lab Higher Secondary School,  
QAED Kasur.

### Supervision

Mr. Jahanzaib Khan  
SS (Computer Science)

### Director Manuscripts

Ms. Rehana Farhat

### Dy. Director (Graphics)

Ms. Aisha Sadiq

### Dy. Director (Sciences)

Mr. Imtiaz Hussain

### Design & Layout

Mr. Aleem Ur Rehman

### Illustration

Mr. Ayat Ullah

Published by: Punjab Curriculum and Textbook Board, Lahore.  
Printed by: NEWISH PRINTERS, LAHORE.

Experimental  
Edition

| Date Of Printing | PMIU    | PEF   | PEIMA | MLWC | SPECIAL EDUCATION | PWWF  | LNFB-CENTRAL PUNJAB | LNFB-NORTH PUNJAB | TOTAL QUANTITY |
|------------------|---------|-------|-------|------|-------------------|-------|---------------------|-------------------|----------------|
| November 2024    | 347,673 | 6,365 | 0     | 0    | 510               | 2,347 | 0                   | 0                 | 356,895        |

**< This textbook is based on Revised National Curriculum of Pakistan 2023 and has been approved by the Board. >**

**All rights are reserved with the Punjab Curriculum and Textbook Board, Lahore.**  
No part of this textbook can be copied, translated, reproduced or used for preparation of test papers, guidebooks, keynotes and helping books.

## Contents

| Unit | Topic   | Page |
|------|---|------|
| 1    | Introduction to Systems                               | 1    |
| 2    | Number Systems  | 24   |
| 3    | Digital Systems and Logic Design                      | 49   |
| 4    | System Troubleshooting                                | 69   |
| 5    | Software System                                       | 87   |
| 6    | Introduction to Computer Networks                     | 99   |
| 7    | Computational Thinking                                | 123  |
| 8    | Web Development with HTML, CSS and JavaScript         | 151  |
| 9    | Data Science and Data Gathering                       | 179  |
| 10   | Emerging Technologies in Computer Science             | 211  |
| 11   | Ethical, Social, and Legal Concerns in Computer Usage | 225  |
| 12   | Entrepreneurship in Digital Age                       | 243  |
| 13   | Answers   | 261  |

بِسْمِ اللَّهِ الرَّحْمَنِ الرَّحِيمِ  
(In the Name of Allah, the Most Compassionate, the Most Merciful.)

# COMPUTER SCIENCE AND ENTREPRENEURSHIP



Based on Revised National Curriculum of Pakistan 2023  
ONE NATION, ONE CURRICULUM



PUNJAB CURRICULUM AND  
TEXTBOOK BOARD, LAHORE

*Received*  
*18/12/24*

## Student Learning Outcomes

**Understand System Theory:**

- Define and describe general system theory, its types, objectives, components, and interactions.
- Explain the concept of a system, including objectives, components, and communication.
- Describe what constitutes a system and its role in various domains.
- Explain the importance of system objectives and common objectives such as processing information, supporting applications, and achieving specific goals.
- Understand the role and importance of system components and their interactions.
- Explain the significance of interactions among various systems.
- Differentiate between natural and artificial systems.
- Categorize and describe various types of natural and artificial systems, their objectives, components, and interactions.
- Provide examples of natural systems, including physical, chemical, biological and psychological systems along with their characteristics.
- Provide examples and functions of artificial systems, including knowledge systems, engineering systems, and social systems.
- Analyze systems to identify their objectives, components, and interactions.
- Compare and contrast different types of systems, highlighting variations in objectives, components, and interactions.
- Conduct research on specific system types and present findings effectively.
- Create diagrams or models to visually represent the structure and interactions of systems.
- Assess the role and importance of system objectives in real-world applications.
- Demonstrate understanding of how systems apply to different fields and serve specific functions.

**Computing Systems**

- Define and describe a computer as a system, including its objectives, architecture, components, and interactions.
- Understand the primary objectives of a computing system, including processing data, executing instructions, and providing a user interface.
- Recognize the role and importance of computer system components and their interactions.
- Identify necessary and auxiliary components of a computer system.
- Identify different types of computing systems, such as computers, software, computer networks, and the Internet.
- Understand the Von Neumann architecture and its core components: CPU, motherboard, memory, storage devices, input/output ports, and devices.
- Explain the relationship between the CPU, memory, and storage, and how data flows within a system.
- Describe how components within a computer system interact to execute tasks, such as how the CPU fetches, decodes, and executes instructions stored in memory.
- Differentiate between the roles of hardware and software in a computer system.
- Define and describe Computing system and its types including Computer, Software, Network and the Internet.
- Describe the main functions of system software, such as operating systems, and application software.

## Introduction

This chapter provides an overview of the theory of systems, introducing fundamental concepts and exploring various types of systems. It begins by defining what a system is, discussing its basic components, objectives, environment, and methods of communication. The chapter then differentiates between natural and artificial systems, explaining how they function and their purposes. The relationship between systems and different branches of science is also explored, including natural science, design science, and computer science. The chapter then shifts back to discussing computers as systems, explaining their goals, parts, and how these parts connect with each other and their surroundings. It provides a detailed look at the Von Neumann computer architecture, exploring its components, how it works, its unique features, as well as its strengths and weaknesses. The chapter also covers different types of computing systems, such as computers, software, networks, and the Internet, clearly explaining their roles and purposes. At the end of this chapter, the reader will be in a better position to understand systems, their classification, and relevance in natural and man-made systems to aid future learning and utilization.

## 1.1 Theory of Systems

The idea of a system is useful to explain both the external reality as well as the internal one. An Information System is simply an organized set of components that are coordinated to perform a designated function. All the components of the system are in some way related to each other and the functioning of the other components enhances the operation of the system.

Let us consider a simple example, such as a car, depicted in Figure 1. 1: it is made up of an engine, wheels, brakes, and other related items. Every part plays a unique task, but collectively they are responsible for making the car move. Likewise, every computer, organism, machine, or device has components that work together to achieve an outcome.

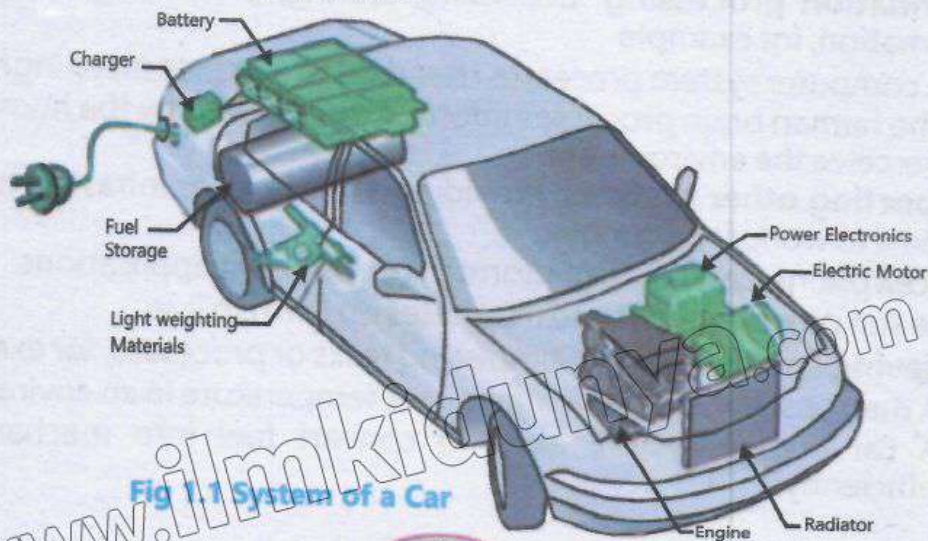

Fig 1.1 System of a Car

## Systems Theory:

A branch of a science that deals with complicated structures in living organisms, that relate the human with society and the science is known as Systems Theory. It gives a way of interpreting the existing world with different varied perspectives, how the different systems and sub-systems operate, how they are integrated, how they grow and how they change with time.

Systems can be observed at all levels of existence, starting with the levels of nature, and going all the way up to levels of systems designed by humans. These can be physical objects—such as a car; processes, such as the university's admission process; or abstract objects such as a mathematical formula. Thinking about how systems operate helps us better understand how they need to be developed and nurtured across different discipline like computing, biology, engineering, and social science. In this section, basic concepts will be introduced to emphasize fundamental concepts and principles.

### 1.1.1 Basic Concepts of Systems

A system is described by its objectives components, communication among components and environment in which it works. The components of a system communicate with each other to achieve the system's objective in an environment. Systems can be simple, like a thermostat, or complex, like the human body or a computer network.

#### 1.1.1.1 Objective

Every system has a purpose or goal that it wishes to fulfil. Analyzing a system's operation requires understanding its aim. This insight improves the efficiency and efficacy of the present system. A transport system aims to transfer people and products securely and effectively between locations. A computer system's principal goal is to process data and provide useful information to users.

#### Types of System Objectives

Systems can have different objectives depending on their nature and purpose. Common objectives include:

- 1. Information processing:** Collecting, storing, processing, and distributing information, for example
  - o A computer system processes user data to produce meaningful outputs.
  - o The human brain processes information received by the human senses to perceive the environment.
- 2. Supporting other systems:** Providing a platform or infrastructure for other systems to work, for example:
  - o A cell phone provides a platform to run different applications.
  - o The sun provides energy to all species on Earth to live.
- 3. Achieving specific goals:** Completing tasks or processes, for example:
  - o A thermostat system maintains a set temperature in an environment.
  - o A car engine system aims to convert fuel into mechanical energy efficiently.



**Brain: Information processing**



**Cell Phone: Supporting other systems**



**Thermostat: Achieving specific goals**

**Fig. 1.2 Types of System Objectives**

### Human Brain System

### Tidbits

1. Your brain is an incredible example of a communication network. Neurons send signals to each other, allowing you to think, move, and experience emotions. This complex communication is what makes our brains so powerful.
2. The brain produces around 20 watts of electrical energy, sufficient to operate a low-wattage LED light bulb. Presented here is the brain's remarkable efficacy as an electrical system.
3. The information traveling through your brain moves at about 268 miles per hour, which is faster than a Formula 1 race car.
4. Your brain, as a biological system, has around 86 billion neurons. If each neuron was a person, it is like the population of about ten Earth all interacting simultaneously!
5. The human brain can perform about  $10^{16}$  (10 quadrillion) operations per second, making it one of the most powerful and efficient biological systems in existence.

### 1.1.1.2 Components

Components are the building blocks of any system. Each component plays a specific role and contributes to the overall functionality of the system. Understanding the role of each component of the system is essential to understand how the entire system works. This helps in identifying problems, improving performance, and refining system design. Smooth and proper working of these components together ensures the system meets its objectives.

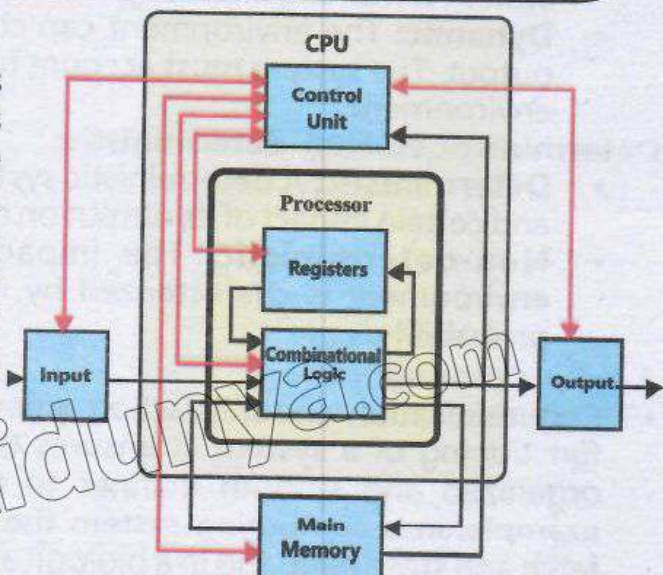

## Human Body and its DNA System

## Tidbits

1. Consider your body as a very sophisticated and effective system. It is a remarkable system comprising subsystems such as the circulatory system, neurological system, and digestive system. The cardiovascular system circulates blood. The respiratory system supplies oxygen, and the cerebral system processes information. Individually, each has a distinct function yet collaborates to ensure our survival and well-being.
2. DNA is like a blueprint for life. It's a system that contains all the instructions for an organism to grow, develop, and reproduce, passed down from generation to generation. Each cell in our body reads this blueprint to know what to do. When all the DNA in a single human cell is extended, it measures about two meters in length. The total long of the DNA in your body extends to the Sun and back more than six hundred times.

### 1.1.1.3 Environment

The environment of a system includes everything external to the system that interacts with it. It consists of all external factors that affect the system's operation. Understanding the environment of a system is important as it influences the system's performance and behavior by providing inputs and receiving outputs. Intelligent systems adjust to changes in their environment to continue their functionality. There are several properties of a system's environment that affect system design and its functionality. Two of these properties are described as follows:

#### Static vs. Dynamic:

- **Static:** The environment remains unchanged unless the system provides an output. There are no changes occurring in the environment while the system is working internally.
- **Dynamic:** The environment can change independently of the system's output. The system must account for changes that occur over time in the environment.

#### Deterministic vs. Non-deterministic:

- **Deterministic:** A deterministic system is characterized by its fully known and certain impact of its output on the environment.
- **Non-deterministic:** The impact of the system's output on the environment is characterized by inherent uncertainty, randomness, or probability.

### 1.1.1.4 Communication

- Communication and interaction among system components is key to the functioning of a system. It ensures that components work together in an organized and smooth manner to achieve the system's objectives. For example, in a computing system the CPU communicates with memory to fetch and store data, and in a biological system brain sends signals to muscles to initiate movement.



## System's Interaction with the Environment

Systems constantly interact with their environment through inputs and outputs. For example, a weather monitoring system receives data from environment sensors and provides the current status of the weather and future forecasts to users. In a computing system, computers interact and communicate with peripheral devices like printers and scanners, and in a biological system animals interact with plants and other animals, forming a food chain.

### Activity: Classroom Discussion, Brainstorming, and System Mapping

**Objective:** To introduce the concept of systems and understand how different components interact within a system.

**Required Material:** Poster boards, markers, sticky notes, chart paper, drawing tools.

**Activity Type:** Group

**Activity Tasks Detail:** Start with a discussion where the teacher introduces the concept of systems using examples like cars and schools. Students will contribute their examples and ideas. Next perform a brainstorming session, where students will work in groups to identify and list the systems they interact with daily. They will then create a system map on poster boards, labeling the components and their interactions. Finally, during a gallery walk, each group will present their system map, followed by a feedback session where the teacher provides feedback and answers questions.

**Output:** Each group will produce a system map poster illustrating their chosen system, and students will enhance their presentation and explanation skills.

### Activity: Design a Simple System

**Objective:** To apply the principles of system design and understand the process of creating a functional system.

**Required Material:** Computers or tablets with diagramming software (e.g., Lucidchart), paper, pencils, markers.

**Activity Type:** Pair

**Activity Tasks Detail:** Begin with an introduction where the teacher presents an example of a simple system. Students will then work in pairs to define the objective of their chosen system, list its components, describe their interactions, and outline the system's environment. The pairs will use diagramming software to create a system prototype or diagram. Finally, they will present their designs to the class in a review and feedback session.

**Output:** Each pair will produce a system prototype or diagram and receive feedback to refine their design ideas.

## 1.2 Types of Systems

Systems can be broadly categorized into two types, namely natural and artificial systems. Understanding the differences and similarities between these types helps us apply system theory across various fields. Natural systems are naturally built and occur in nature without human intervention. While artificial systems are created by humans to fulfill specific needs or purposes.



Galaxy a Natural System

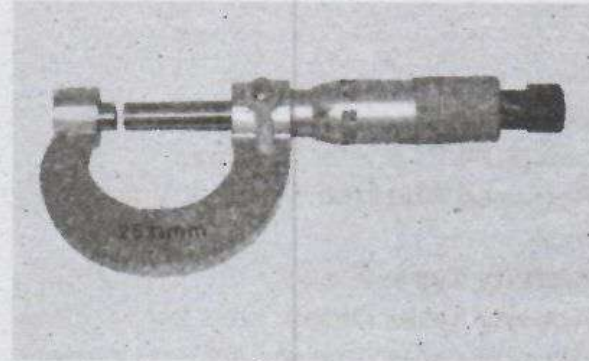

Screw gauge an Artificial System

Fig. 1.4 Examples of Systems

### 1.2.1 Natural Systems

Natural systems are those that exist in nature and operate independently of human involvement. They are governed by natural laws and processes. Natural systems are of various forms and sizes, from very tiny objects like atoms and cells in our body to very huge like forests, oceans and the cosmos. Following are examples of some natural systems that exist in nature.

#### 1.2.1.1 Physical Systems

Physical systems are composed of physical components and governed by the laws of physics. They include things ranging from sub atomic particles, atoms, to planets, stars, galaxies, and cosmos. Physical systems, like any kind of matter, emerge from the interactions of electrons, protons, neutrons and sub-atomic particles which are governed by electric and atomic forces. For example hydrogen gas ( $H_2$ ) is formed when an electron, proton, and neutron combine, following the rules of physics and natural forces.

#### 1.2.1.2 Chemical Systems

Chemical systems involve substances and their interactions, transformations, and reactions. They are governed by the laws of chemistry. Chemical systems emerge from physical systems when atoms and molecules interact and bond according to chemical principles, forming new substances. For example, a chemical system like water ( $H_2O$ ) is formed when hydrogen atoms bond with oxygen atoms, following chemical rules and reactions.

#### 1.2.1.3 Biological Systems

Biological systems consist of living organisms and their interactions. They are governed by biological processes such as growth, reproduction, and metabolism. Biological systems emerge from chemical systems when molecules

interact in complex ways to form living cells, which then organize into tissues, organs, and organisms.

#### 1.2.1.4 Psychological Systems

Psychological systems involve the mind and behavior. They include thoughts, emotions, and mental processes, governed by the principles of Psychology. Psychological systems emerge from biological systems when the brain's physical and chemical processes give rise to thoughts, emotions, and behaviors, which are influenced by an individual's experiences and environment.

##### Activity : Interactive Simulation

The purpose of this activity is with the aim of understanding how variability affects the system of interest.

**Materials Needed:** Computers or tablets with internet access and online simulation tools (like an ecosystem simulator).

**Activity Tasks Detail:** Individual or Group Assignments The teacher will begin by explaining what system dynamics entail as well as provide an overview on how the simulation will be implemented. Students will then work with the simulation tool, manipulating different variables and analyzing how the system reacts. Using an S-curve to review their results, the students will be reflecting on how changes impact the entire system during the discussion. The teacher will emphasize that all these parts are integrated and balanced, and the students will follow this aspect during their conversation.

**Outcome:** They produce detailed observation notes as well as better insights into system dynamics and balance.

#### 1.2.2 Artificial Systems

Artificial systems are created and developed by people so that they may fulfill certain functions or address certain issues. These systems can be as small as a wheel or as large as the United Nations. Each system is designed very deliberately to perform the task, improve the efficiency of the processes, and provide solutions to various issues in different sectors.

Artificial systems are a vital part of the contemporary society because they reinforce productivity, solve complex problems, and improve people's well-being. These are systems such as knowledge management systems, engineering achievement systems and indeed social systems which are the framework of success of human civilization. There are different types of artificial systems, some of which are described below:

##### 1.2.2.1 Knowledge Systems

A knowledge system is unique because it is developed to capture, process, facilitate, store, retrieve and manage information. Such systems facilitate in managing and utilizing the resources of knowledge effectively for the purpose of decision-making, learning and problem-solving.

1. **Mathematics:** Mathematics is a field of knowledge, which is studied to focus problems connected to numbers, their amounts, forms, structures, and patterns.
2. **Logic:** Logic is a theoretical model consisting of concepts and strategies on identifying and assessing rationale. That is why it is a basis of all logical thinking processes and practice of critical analysis.
3. **Databases:** A database system can best be described as software for managing data, particularly to enable easy retrieval, management, and updating of data. Some of the examples are relational database management system like MySQL while others are NoSQL database management system like MongoDB.
4. **Information Management Systems:** These are specific applications developed with the purpose of capturing, archiving, organizing, and disseminating data.

#### 1.2.2.2 Engineering Systems

Products developed by engineers are complex frameworks or devices that apply engineering concepts to perform certain tasks or solve technical challenges. These are some examples of how engineers of various types develop systems according to their own special knowledge and perspective, given to them through their original visions and approaches.

1. **Civil Engineering Systems:** Concentration on developments such as constructing houses, roads, bridges and even maintaining these structures. For instance, a structure used to provide a passage over water, valleys or roads is termed a bridge.
2. **Mechanical Engineering Systems:** Engage in planning and creating devices that make utilization of forces from outside to accomplish work. For instance, a robotic arm applied in assembly line for packaging of products in factories.
3. **Chemical Engineering Systems:** Focuses on converting raw materials into useful products through chemical processes, considering internal molecular interactions. For example, a water treatment plant that purifies water using chemical processes like coagulation and filtration.
4. **Electrical Engineering Systems:** Involves the study and application of electricity, electronics, and electromagnetism to develop electrical systems. For example a home automation system that controls lighting, heating, and security using a smartphone app. This system uses electric signals and power to operate various home appliances and systems remotely.
5. **Software Engineering Systems:** Is the process of designing, developing, and maintaining software to perform certain tasks eradicating errors. For instance, an online tool assisting a library in tracking books, users as well as stocks in their possession.

**Artificial Engineering System**

- The Metro Train System in Lahore is an artificial system created for efficient transportation. The railway system consists of tracks, trains, stations, and control systems that transport people between locations.
- The first electric traffic lights were built in Cleveland, Ohio, in 1914. Modern traffic systems use smart sensors and AI to enhance safety and flow.
- AI systems, such as Siri and Alexa, can recognize and respond to human speech. These examples demonstrate how computer systems may interact with humans naturally through complicated algorithms and data processing.
- Virtual Reality (VR): Immersive digital worlds enable exploration and interaction as if you were physically present. This technology has several applications, including gaming, teaching, and astronaut training.

**1.2.2.3 Social Systems**

Social systems refer to structured frameworks established by individuals to effectively handle social interactions, organizational governance, and communal endeavors. The basic goal of these systems is to maintain order, provide services, and facilitate social connections.

- 1. Academic institutions:** are entities that provide educational services to students. Schools, colleges, and universities are examples of educational institutions that provide instruction via the use of administrative, teaching, and support staff.
- 2. Governments:** Organizational institutions that wield authority and control over a community or country. Examples include democratic systems, where representatives are elected and authoritarian regimes, where power is centralized.
- 3. Organizations:** are entities formed to achieve specific goals and are often structured hierarchically with well-defined roles and responsibilities. Examples include corporations like Apple and non-profit organizations such as the Edhi Foundation.

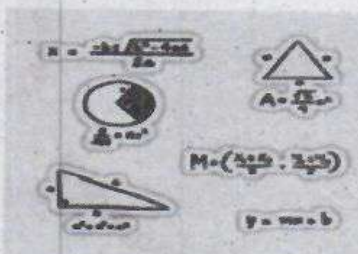

Mathematics a Knowledge System

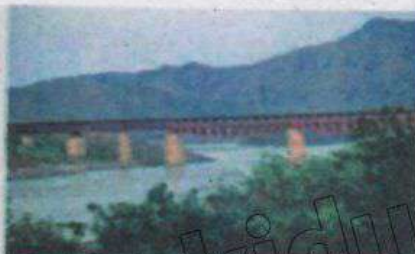

Attock Bridge an Engineering System



Punjab University a Social System

Fig 1.5 Types of Artificial Systems

Activity: Simulation Game

**Objective:** To experience managing a system and making decisions to keep it functional.

**Required Material:** Computers or tablets with internet access, city simulation game (e.g., SimCity).

**Activity Type:** Pair (Group of two students)

**Activity Tasks Detail:** Begin with an introduction to the simulation game, explaining its objectives and mechanics. Students will then play the game in pairs, making strategic decisions to manage their city. After gameplay, a debriefing session will allow students to discuss their experiences, challenges, and strategies. The teacher will link these experiences to system management concepts discussed in class.

**Output:** Hands-on gameplay experience and reflection on system management challenges and strategies.

### 1.3 System and Science

Knowledge is our understanding of various systems in the universe around and within us. Science is a systematic way to validate this understanding. Science can be divided into two main types: natural science and design science. Both natural and design sciences study systems, but they approach them differently. In natural science, scientists study existing natural systems to understand their workings. While in design science, scientists create new systems (artifacts) to solve problems or achieve specific goals. Each type of science addresses different systems and questions, and therefore follows different scientific methods.

#### 1.3.1 Natural Science

Natural science is meant to uncover the objectivity and functionality of natural systems in the natural world. Its nature is descriptive, meaning that the scientists seek to understand and describe natural phenomena. To achieve this, natural scientists follow the empirical cycle of natural science, as shown in Figure 1.6.



Fig. 1.6 Empirical Cycle of Natural Science

### 1.3.2 Design Science

- Design Science is focused on designing and creating artifacts (tools, systems, methods) to achieve specific goals. The nature of design science is prescriptive, meaning that it aims to prescribe and create artificial systems. To achieve this design science researchers follow the regulative cycle.

#### Examples

- **Natural Science:** Studying the ecosystem of a forest to understand how different species interact (descriptive).
- **Design Science:** Developing a new software system to manage forest data and improve conservation efforts (prescriptive).

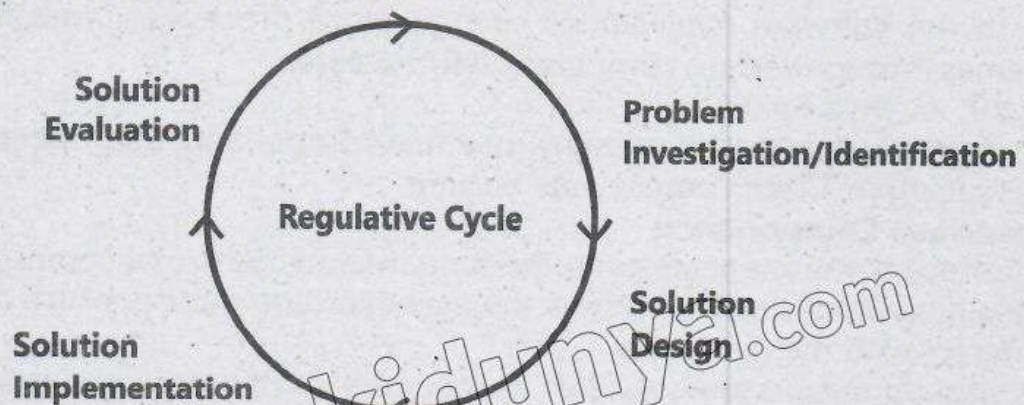

Fig. 1.7 Regulative Cycle of Design Science

### 1.3.3 Computer Science

Computer science is the study of how computers work, including at what they can do and their limitations. To understand computer science, we use methods of both design science and natural science.

#### 1.3.3.1 Natural Science of Computer Science

Natural science of computer science focuses on finding the basic rules that control how computer systems work. This involves the study of various algorithms and their characteristics.

- **Study of Algorithms:** Researchers analyze existing algorithms to understand their efficiency and limitations. For example, studying different sorting algorithms and their characteristics which arrange given data in an order, like QuickSort or MergeSort. To understand their speed and how they perform with different kinds of data.

#### 1.3.3.2 Design Science of Computer Science

Design science of computers focuses on creating and improving computer tools and systems to make them work better.

- **Development of New Software Tools:** Researchers create new tools or applications to solve specific problems. For example: Designing a new programming language that makes it easier for developers to write secure computer programs.

- **Improvement of Computer Systems:** Researchers work on enhancing existing systems to perform better. For example, creating a more efficient database management system that can handle larger amounts of data faster and with fewer errors.

#### 1.4 Computer as a System

A computer is a complex system designed to process data and perform tasks according to a set of instructions.

##### 1.4.1 Objective

The main objective of a computer is to perform computations, process data, and execute different tasks efficiently. For example, a personal computer's objective is to run software applications such as word processors, web browsers, and games through various computational processes.

##### 1.4.2 Components

A computer composed of many essential components that operate in conjunction. These components include:

###### Interface Components:

Interface components refer to the fundamental parts of a computer system, including input devices such as the keyboard and mouse, which allow users to interact with the computer.

Computer output devices, such as monitors and printers, are used to present or generate results from the computer's operations.

###### Processing Components:

- The processing components of a computer consist of the CPU, which acts as the Central Processing Unit responsible for computations and executing command.
- Random Access Memory (RAM) is a transient storage that stores data and instructions for the CPU, whereas Storage (Hard Drive or SSD) is a permanent storage for data and software needed for future processing.
- The operating system is responsible for receiving information from interface components and determining the appropriate actions to take.
- Application software refers to programs that are executed by the operating system when required to perform one or more specified tasks.

###### Communication Components:

Communication components in a computer refer to the physical elements that provide communication between different components of the computer.

- In a computer, the motherboard serves as the primary circuit board that interconnects all components by using cables and circuits.
- A system bus is a collection of electrically conductive cables that transmit data between the CPU and all other interconnected components. There are three distinct types of buses: data bus, address bus, and control bus. These buses provide the flow of data, the address of data or instructions, and control signals from the CPU to other components concurrently.





Fig. 1.8 Computer System and its components

### 1.4.3 Interactions among Components

The components of a computer interact with each other to perform tasks. For example when you open a file using your mouse or keyboard, several components of your computer interact seamlessly to make this action happen. Here's a step-by-step explanation of the process:

1. User Action or Input. You double-click on a file icon using your mouse or press a key combination to open a file. For example you double-click on a document named "report.docx" on your desktop.
2. Input Device. The mouse or keyboard sends a signal to the computer indicating that you want to open the file. For example, the mouse sends sensory input to the computer's operating system through the USB connection.

#### Activity: The Journey of Data

**Objectives:** Students will discover how computer components work together to process and display data.

**Required Material:** Markers, index cards, and a flowchart template are required.

**Pair-based activity:** Tasks Begin with an introduction to data processing in computers. Students will work in pairs to create a flowchart illustrating the data stream from input to output. Each pair will present their flowcharts and participate in a class discussion to highlight key points.

**Output:** Improved presentation and debating skills, as well as thorough flowcharts depicting the data path.

#### 1.4.4 Environment

The computer system environment includes any external devices that interact with the computer. For example:

- **Power Supply:** Provides electrical power to allow the computer to work.
- **Network:** Connects the computer to other systems and the Internet.
- **Peripherals:** Include printers, scanners, and external discs that expand the computer's capabilities.

#### 1.4.5 Interaction with the Environment

A computer interacts with its environment to perform its functions. For examples:

- **User Input:** A user types on the keyboard, and the computer processes the input to display text on the screen.
- **Network Communication:** The computer sends and receives data over the internet to browse websites or download files.
- **Power Supply:** The computer relies on a stable power supply to function correctly.

#### Activity: Exploring Computer Components

**Objective:** Students will learn about the different components of a computer and their functions.

**Required Material:** Physical computer parts (CPU, RAM, etc.), diagrams of computer systems, worksheets for labeling and note-taking.

**Activity Type:** Group (Small groups of 3-4 students)

**Activity Tasks Detail:** The teacher will start with an overview of key computer components. Students will then work in small groups identifying and labeling computer parts using worksheets. Groups will present their findings in a session, followed by a Q&A where the teacher clarifies any misunderstandings.

**Output:** Labeled worksheets, enhanced presentation skills, and a deeper understanding of computer components.

### 1.5 The Architecture of von Neumann Computers

The Von Neumann architecture is a computer paradigm that delineates a system in which the hardware of the computer has four primary components: the memory, the Central Processing Unit (CPU), input mechanisms, and output mechanisms. This model is called the John von Neumann model, the Neumann model named in honor of the mathematician and physicist who contributed to its development during the 1940s.

#### 1.5.1 Components

Now we will look at brief overview of the key parts that constitute the architecture of the von Neumann computer.

1. **Memory:** Contains both input data and the instructions (program) required for CPU processing. For instance, consider the RAM of your computer: when a program starts it is loaded into RAM to enable faster execution compared to when it runs from the hard disk.
2. **Central Processing Unit (CPU):** Performs addition and subtraction, and executes commands provided by the memory. The system has two main components: the Arithmetic Logic Unit (ALU) and the Control Unit (CU). The Arithmetic Logic Unit (ALU) performs mathematical computations and logical operations.

A Control Unit (CU) is a peripheral that governs the activities of the CPU by instructing the ALU and memory to execute tasks according to the program instructions. It ensures the proper and timely execution of duties by all the other components.

When doing the calculation  $2 + 2$  on a calculator application, the Arithmetic Logic Unit (ALU) handles the numerical values while the control Unit (CU) supervises the whole procedure.

3. **Input Devices:** Enable users to input data and instructions into the computer system.

Illustrative examples include keyboard, mouse, and microphone. Entering text on the keyboard transmits data to the CPU for subsequent processing.

4. **Output Devices:** Present or communicate the outcomes of the tasks executed by the computer.

Consider, for instance, a monitor and printer. Upon completion of data processing, the CPU transmits the outcome to the monitor for visual display.

A system bus is a communication mechanism that facilitates the movement of data between components inside a computational system. It comprises:

Data Bus: Transports data.

Address Bus: Maintains data destination information.

Control Bus: Transports control electrical signals.

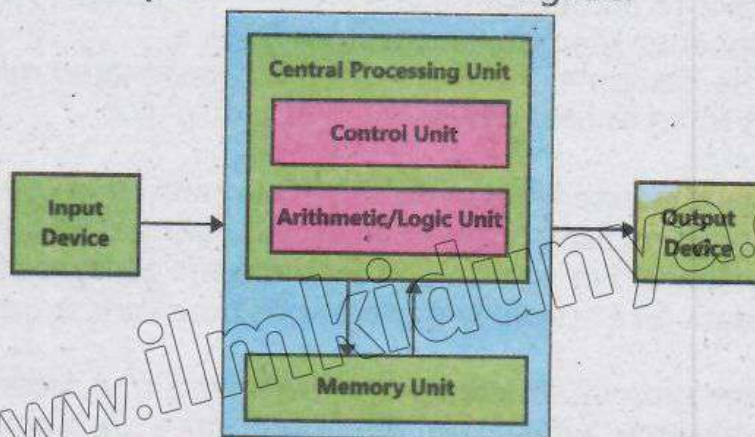

Fig. 1.9 Von Neumann computer Architecture

### 1.5.2 Working

The Von Neumann architecture encompasses three essential stages for a CPU to carry out instructions, namely retrieval, interpretation, execution, and storage. To demonstrate this procedure, we will use the example two-digit addition with a basic calculator application.

- **Fetching:**

Description: The central processing unit retrieves an instruction from the computer's memory. This instruction specifies the operation to be executed by the CPU.

Hardware Components: Memory, CPU (Program Counter (PC), Instruction Register (IR)).

Specification: The Program Counter (PC) stores the memory address of the subsequent instruction. Once the address is stored in memory, the instruction located at that location is retrieved and placed into the Instruction Register (IR).

- **Decoding:**

In order to determine the necessary action, the Control Unit (CU) decodes the instruction.

Comprising Components: Control Unit (CU).

Detail: The control unit (CU) decodes the opcode (operation code) of the instruction and determines the required procedures and data.

- **Execution:**

Description: The CPU processes the instruction. When the instruction involves a computation, it is executed by the Arithmetic Logic Unit (ALU).

Any task that requires transferring data between several locations is managed by the CU.

Involved Components: ALU, CU.

Detail: The Arithmetic and Logic Unit (ALU) carries out mathematical and logical calculations, while the Control Unit (CU) handles data transmission activities.

- **Storing:** Description: The outcome of the computation is either returned to memory or sent to an output device.

Involved Components: Memory and Output Device.

Specification: The outcome is either stored in a designated memory location or sent to an output device, such as a display.

### 1.5.3 Characteristics

Following are the key characteristics of the Von Neumann computer architecture

1. **Single Memory Store:** Both program instructions and data are stored in the same memory space. For example in a computer game, both the game's code and the data (like scores and player positions) are stored in the same RAM.
2. **Sequential Execution:** Instructions are processed one after another in a sequence. For example, when your computer runs a program, it follows the steps one by one in the order they are written.

3. **Stored Program Concept:** Programs are stored in memory and can be changed by the computer. For example, when you update a software program, the new instructions replace the old ones in memory.

#### 1.5.4 Advantages and Disadvantages

The advantages and disadvantages of Von Neumann computer architecture are discussed here.

##### Advantages:

- **Simplified Design:** By combining instructions and data into a single memory area, architecture is simplified.
- **Flexibility:** Programs can be easily changed by changing memory contents.

##### Disadvantages:

- **The Von Neumann bottleneck** occurs when a single memory area limits the CPU's ability to retrieve instructions and data quickly.
- **Security Risks:** Having data and instructions stored in the same area poses a problem where one program can alter another's instructions in a manner that is security risk. The Von Neumann architecture is a key important aspect of the design and structure of many computers, serving as a central model on how they operate. It is like a recipe fed into the computer, which follows it exactly ensuring that both data and instructions are properly processed. However, this model has been essential in the evolution of computing technology, despite its limitation.

#### 1.6 Computing Systems

A computer system is a structured set of hardware and software components specifically designed for data processing and the performance of various operations. These systems can range from simple technological tools, such as calculators used for performing mathematical calculations to complex network of linked computers. The basic task of a computer system is to execute program and manage data to achieve objectives such as problem solving, process control and communication aid. Hardware, software, and electric power are the three basic requisites that are needed to run a computing system and can be described in the following simple terms.

- **Hardware** of a computer system refers to the tangible components of the system. These include the Central Processing Unit (CPU), Random Access Memory (RAM), storage devices, and input and output devices.
- **Software** refers to a collection of instructions that dictate the requirements and actions that hardware must do. There exist two primary categories. System software and application software. System software encompasses the Operating System (OS) and utility applications responsible for managing the computer's resources, such as Windows, macOS, and Linux distributions. Application software refers to software applications that are specifically developed to carry out certain functions for the user, such as word processors, web browsers, and games.

- **Electricity:** Electricity is the power source that enables the hardware components to function. Without electricity, the hardware components cannot function, and the computing system will not operate.

### 1.6.1 Types of Computing Systems

Computing systems come in various types, some of these include the followings:

1. Computer,
  2. Software Systems,
  3. Computer Networks, and the
  4. Internet.
- Computers as a system has been discussed in previous sections, while the remaining two computing systems are described in this section.

### 1.6.2 Computer Network as Systems

A computer network connects multiple computers and devices, enabling the efficient exchange of resources and information.

#### 1.6.2.1 Objectives

- **Resource Sharing:** Allow multiple users to share resources like files, printers, and internet access within an office or other settings.
- **Communication:** Enable efficient communication between devices and users.
- **Data Management:** Facilitate easy data management and collaboration.

#### 1.6.2.2 Components

##### • **Networking Hardware:**

**Routers:** Routers are devices that transmit data packets between their networks.

**Switches:** Switches connect devices in a network and facilitate communication.

**Network Cables:** A physical medium for data transfer.

##### • **Network Software:**

**Protocols:** Rules and conventions for data exchange such as TCP/IP.

**Network Operating Systems:** Software that manages network resources, such as Windows Server.

#### 1.6.2.3 Environment

A computer network operates in various environments, such as office buildings, data centers, or across the globe via the Internet. The environment influences network design, security, and performance.

#### 1.6.2.4 Types of Computer Networks

- **Local Area Network (LAN):** Connects computers in a specific area, such as a single building or school. For example, an office network that connects everyone. Employee PCs and printers.
- **Wide Area Network (WAN):** connects computers across larger geographic regions, such as cities, nations, and even continents. For example, consider the Internet which links computers worldwide.
- In summary, a computer network is an important system that enables resource sharing and communication among connected devices, using hardware and software components that work together seamlessly to perform various tasks.

### 1.6.3 Internet as a System

The Internet is a vast and complex system designed to connect multiple networks worldwide, including private, public, academic, business, and government networks. Its primary objective is to facilitate communication and data exchange between computers and users globally.

#### 1.6.3.1 Internet Protocols

- TCP/IP (Transmission Control Protocol/Internet Protocol): The core protocols that govern data transmission over the Internet.
- User Datagram Protocol (UDP): Faster but less reliable.
- File Transfer Protocol (FTP): Used for transferring files between computers.
- Post office Protocol (POP): Used for retrieving emails from server/network.

#### 1.6.3.2 Interaction among Components

The components of the Internet interact with each other to perform different tasks. For example when a user requests a web page through a web browser, several components of the Internet work together to display its contents on the user's screen.

#### 1.6.3.3 Environment

The Internet operates in a diverse and dynamic environment, connecting various types of networks across different locations, including homes, offices, data centers, and mobile networks. This environment influences the design, security, and performance of the Internet.

#### Activity: Computing Systems Around Us

**Activity Tasks Detail:** Start with an introduction on computing systems. Students will then research and list various computing systems they use daily, completing a worksheet. In a group sharing session, students will discuss their findings. The class will engage in a discussion to highlight key points, and students will begin preparing a short presentation on a computing system for the next class.

**Output:** Completed worksheets, group insights, and a short presentation on a chosen computing system.

#### Internet Systems

1. When you send an email or browse the internet, data travels through cables and airwaves across the world in just seconds. It's like sending a letter that gets delivered instantly, regardless of distance!
2. The internet is one of the largest man-made systems ever created. It's a vast network of interconnected computers that communicate with each other to share information, much like how our brain's neurons communicate. When you send a message, it travels through multiple networks before reaching its destination, all within seconds.
3. Data on the internet travels at nearly the speed of light! When you send a message or browse a website, your data can cross continents almost instantaneously.
4. There are over 1.5 billion websites on the internet today, and more than 4 billion people are connected to the internet globally. That's more than half of the world's population!

#### Tidbits

## Summary

- A system is a collection of parts that work together to achieve a common goal.
- A system is described by its objective, components, communication among components and environment in which it works.
- Components are the building blocks of any system. Each component plays a specific role and contributes to the overall functionality of the system.
- The environment of a system includes everything external to the system that interacts with it. It consists of all external factors that affect system's operation.
- Systems can be broadly categorized into two types, namely natural and artificial systems.
- Natural systems are those that exist in nature and operate independently of human involvement.
- Artificial systems are designed and constructed by humans.
- Social systems are organized structures created by humans to manage social relationships, governance, and community activities.
- Computer science is the study of how computers work. It looks at what computers can do and what limitations they have.
- A computer is a complex system designed to process data and perform tasks according to a set of instructions.
- The Von Neumann architecture involves several key steps for a CPU to execute instructions, including fetching, decoding, executing, and storing.
- System software is the basic software that helps a computer run and manage its hardware and software resources.
- Application software is the software designed to help users perform specific tasks or activities.





## Multiple Choice Questions

1. What is the primary function of a system?
  - a) To work independently
  - b) To achieve a common goal
  - c) To create new systems
  - d) To provide entertainment
2. What is one of the fundamental concepts of any system?
  - a) Its size
  - b) Its objective
  - c) Its age
  - d) Its price
3. What is an example of a simple system?
  - a) A human body
  - b) A computer network
  - c) A thermostat regulating temperature
  - d) The Internet
4. What type of environment remains unchanged unless the system provides an output?
  - a) Dynamic
  - b) Static
  - c) Deterministic
  - d) Non-deterministic
5. What are the basic components of a system?
  - a) Users, hardware, software
  - b) Objectives, components, environment, communication
  - c) Inputs, outputs, processes
  - d) Sensors, actuators, controllers
6. What concept does the theory of systems aim to understand?
  - a) Hardware design
  - b) System interactions and development over time
  - c) Software applications
  - d) Network security
7. What role does the Operating System (OS) play in a computer?
  - a) It performs calculations and executes instructions
  - b) It temporarily stores data and instructions for the CPU
  - c) It receives input from interface components and decides what to do with it
  - d) It provides long-term storage of data and software
8. Which of the following describes the Von Neumann architecture's main characteristic?
  - a) Separate memory for data and instructions
  - b) Parallel execution of instructions
  - c) Single memory store for both program instructions and data
  - d) Multiple CPUs for different tasks
9. What is a disadvantage of the Von Neumann architecture?
  - a) Complex design due to separate memory spaces
  - b) Difficult to modify programs stored in memory
  - c) Bottleneck due to single memory space for instructions and data
  - d) Lack of flexibility in executing instructions

10. Which of the following transports data inside a computer among different components?

- a) Control Unit                      (b) System Bus  
c) Memory                              (d) Processor

**Short Questions:**

1. Define a system. What are its basic components?
2. Differentiate between natural and artificial systems.
3. Describe the main components of a computer system.
4. List and describe the types of computing systems.
5. What are the main components of the Von Neumann architecture?
6. What is the Von Neumann computer architecture? List its key components.
7. What are the four main steps in the Von Neumann architecture's instruction cycle?
8. What is the Von Neumann bottleneck?
9. What is a key advantage of the Von Neumann architecture?
10. What are the three main requirements for a computing system to function?

**Long Questions**

1. Define and describe the concept of a system. Explain the fundamental components, objectives, environment, and methods of communication within a system.
2. Differentiate between natural and artificial systems. Discuss their characteristics, functions, and purposes with relevant examples.
3. Examine the relationship between systems and different branches of science, including natural science, design science, and computer science. How do these branches utilize system theory to understand and improve their respective fields? Provide specific examples to support your analysis.
4. Explore the different types of computing systems such as computers, software systems, computer networks, and the internet.
5. Describe the main characteristics of a computer as a system, including its objectives, components, and interactions among these components.
6. Explain the Von Neumann architecture of a computer. Include a discussion on the main components, their functions, and the step-by-step process of how the architecture operates.
7. Provide a detailed explanation of how a computer interacts with its environment. Include examples of user input, network communication, and power supply.
8. Describe the process of retrieving and displaying a file using a computer, based on the interactions among different components. Provide a step-by-step explanation of how input is processed, data is transferred, and results are displayed on the screen.